



ETA-Danmark A/S
Göteborg Plads 1
DK-2150 Nordhavn
Tel. +45 72 24 59 00
Internet www.etadanmark.dk

Authorised and notified according
to Article 29 of the Regulation (EU)
No 305/2011 of the European
Parliament and of the Council of 9
March 2011

MEMBER OF EOTA



European Technical Assessment ETA-22/0062 of 2022/03/27

I General Part

Technical Assessment Body issuing the ETA and designated according to Article 66 of the Regulation (EU) No 305/2011: ETA-Danmark A/S

Trade name of the construction product:

ArmaProtect CT

Product family to which the above construction product belongs:

Fire stopping product – penetration seals.

Manufacturer:

Armacell GmbH
Robert-Bosch-Strasse 10
DE-48153 Münster
Tel.: +49 251 76030
Internet: www.armacell.com

Manufacturing plant:

Armacell GmbH
Manufacturing Plant 73

This European Technical Assessment contains:

22 pages including 5 annexes which form an integral part of the document

This European Technical Assessment is issued in accordance with Regulation (EU) No 305/2011, based on:

European Assessment Document (EAD) No. 350454-00-1104 Fire Stopping and fire sealing products – Penetration seals

This version replaces:

-

Translations of this European Technical Assessment in other languages shall fully correspond to the original issued document and should be identified as such.

Communication of this European Technical Assessment, including transmission by electronic means, shall be in full (excepted the confidential Annex(es) referred to above). However, partial reproduction may be made, with the written consent of the issuing Technical Assessment Body. Any partial reproduction must be identified as such.

II SPECIFIC PART OF THE EUROPEAN TECHNICAL ASSESSMENT

1 Technical description of product and intended use

Technical description of the product

The construction products consist of PVC-U half-pipes and an inlay made of an intumescent material which expands under heat exposure.

- In the case of the construction product ArmaProtect CT, design variant 1, two half-pipes are joined by means of a click fastener to form a pipe sleeve. The inlay is bonded into the half-pipes (see Annex 3).
- In the case of the construction product ArmaProtect CT, design variant 2, two half-pipes are joined by means of a fastener taking the shape of an H profile to form a pipe sleeve. The half-pipes are coated with the inlay (see Annex 3).
- The construction product ArmaProtect CT ML consists of a half-pipe. The inlay is bonded into the half-pipe. The inlay overlaps the half-pipe by about the half-pipe's diameter. This overlap is used to form the bottom (see Annex 4).

A detailed technical description (e.g., dimensions) and fire safety related performance criteria for the construction products are given in Annexes 1 to 4.

Detailed information on the construction product components are deposited with ETA-Danmark A/S.

2 Specification of the intended use in accordance with the applicable EAD

The construction product ArmaProtect CT and ArmaProtect CT ML shall be used as part of cable penetration seals.

Cable penetration seals are used to seal openings in fire-resistant walls or floors, which are penetrated by cables. Their aim is to preserve the walls' or floors' fire resistance in the area of the penetrations.

Within the framework of this ETA, the fire resistance was demonstrated for cable penetration seals consisting of two half-pipes of the type ArmaProtect CT (for floor and wall installations) and for cable penetration seals consisting of one half-pipe of the type ArmaProtect CT ML (for wall installations).

The cable penetration seals had a closure made of a flexible foam on both sides for ArmaProtect CT pipe sleeves or one side for ArmaProtect CT ML half-pipes.

After inserting the foam into the remaining openings, this closure was sealed from the outside with an ablative fire stopping product.

In addition, the joints between the pipe sleeve or the half-pipe and the surrounding component were sealed.

More detailed information and data on the verified cable penetration seals are given in annexes 5 to 9.

The construction product ArmaProtect CT and ArmaProtect CT ML may be used for cable penetration seals of use category X (outdoor use – rain, UV light, frost) provided that the other components of the cable penetration seal, which are not the subject of this ETA, meet the durability requirements. The resistance to fire of the cable penetration seals shall be verified on a case-by case basis.

The performances given in Section 3 apply exclusively to the cable penetration seals assessed as part of the ETA procedure (e.g. with respect to the design and arrangement of the cable penetration seals' components as well as the type and position of the services).

The provisions made in this European Technical Assessment are based on an assumed intended working life of the ArmaProtect CT and ArmaProtect CT ML of 10 years, provided the manufacturers conditions for the packaging, transport, storage, installation, use, maintenance and repair are met.

The indications given on the working life cannot be interpreted as a guarantee given by the producer or Assessment Body but are to be regarded only as a means for choosing the right products in relation to the expected economically reasonable working life of the works.

3 Performance of the product and references to the methods used for its assessment*

Characteristic	Assessment of characteristic
3.1 Safety in case of fire (BWR2)	
Reaction to fire	<p>The Half-pipe is classified as E in accordance with EN13501-1, and the EC Delegated regulation 2016/364/EU.</p> <p>The "Inlay" for ArmaProtect CT, design variant 1 and ArmaProtect CT ML is classified as E in accordance with EN13501-1, and the EC Delegated regulation 2016/364/EU.</p> <p>The "Inlay" for ArmaProtect CT, design variant 2 is classified as Class B-s1,d0 in accordance with EN13501-1, and the EC Delegated regulation 2016/364/EU.</p>
Resistance to fire	<p>Classification according to EN 13501-2: See Annex 2 for further information of fire-resistant designs.</p>
3.2 Hygiene, health, and the environment (BWR3)	
Content, emission and/or release of dangerous substances	No dangerous substances
Air permeability (material property)	No performance assessed
Water Permeability (material property)	No performance assessed
3.3 Safety and accessibility in use (BWR4)	
Mechanical resistance and stability	No performance assessed
Resistance to impact/movement	No performance assessed
Adhesion	No performance assessed
Durability	<p>The product fulfils the provisions related to durability in EAD 350454-00-1104 for use condition X.</p>
3.4 Protection against noise (BWR5)	
Airborne sound insulation	No performance assessed
3.5 Energy Economy and heat retention (BWR6)	
Thermal properties	No performance assessed
Water vapour permeability	No performance assessed

*) See additional information in section 3.9 – 3.10.

3.9 Methods of verification

The characteristic values of the sealing system are based on the EAD 350454-00-1104 Fire stopping and fire sealing products - Penetration seals.

3.10 General aspects related to the fitness for use of the product

The European Technical Assessment is issued for the product based on agreed data/information, deposited with ETA-Danmark, which identifies the product that has been assessed and judged. Changes to the product or production process, which could result in this deposited data/information being incorrect, should be notified to ETA-Danmark before the changes are introduced. ETA-Danmark will decide if such changes affect the ETA and consequently the validity of the CE marking based on the ETA and if so whether further assessment or alterations to the ETA, shall be necessary.

ArmaProtect CT and ArmaProtect CT ML is manufactured in accordance with the provisions of this European Technical Assessment using the manufacturing processes as identified in the inspection of the plant by the notified inspection body and laid down in the technical documentation.

4 Attestation and verification of constancy of performance (AVCP)

4.1 AVCP system

According to the decision 1999/454/EC of the European Commission, as amended, the system(s) of assessment and verification of constancy of performance is system 1 (see Annex V to Regulation (EU) No 305/2011).

5 Technical details necessary for the implementation of the AVCP system, as foreseen in the applicable EAD

Technical details necessary for the implementation of the AVCP system are laid down in the control plan deposited at ETA-Danmark prior to CE marking

Issued in Copenhagen on 2022-03-27 by

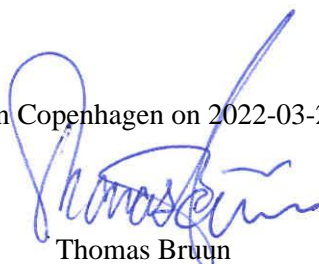

Thomas Bruun
Managing Director, ETA-Danmark

Annex 1

Description of the construction products, properties and performances

The factory manufactured construction products ArmaProtect CT and ArmaProtect CT ML consist of PVC-U half-pipes and an inlay made of an intumescent material. They are used for cable penetration seals.

Properties and performance criteria of the components of the construction products ArmaProtect CT and ArmaProtect CT ML

Component	Description
"Half-pipe" (with glued groove bar or click fastener)	Dimensions: $\varnothing = 60 \text{ mm}, 90 \text{ mm}, 116,4$; $s = 3,2 \text{ mm}$ (depending on the version); $l = 150 \text{ mm}, 200 \text{ mm}$ or 300 mm Material: PVC-U according to EN 1452
"Inlay" for ArmaProtect CT, design variant 1 and ArmaProtect CT ML	ArmaProtect FW2 Thickness = $1,5 \text{ mm}$ (dry layer thickness) Material: intumescent material* Classification of fire behavior according to EN 13501-1: E
"Inlay" for ArmaProtect CT, design variant 2	ArmaProtect FW1 Thickness = $1,5 \text{ mm}$ (dry layer thickness) Material: intumescent material* Classification of fire behavior according to EN 13501-1: B-s1, d0

Description of the additional ingredients of the tested cable penetration seals

"Closure" (for closing the pipe sleeve)	Thickness = 40 mm ; diameter corresponding to the pipe diameter; Material: flexible foam of the type "Basotect" or "Basotect G" der Fa. BASF AG Classification of fire behavior acc. to EN 13501-1: C-s1, d0
"Sealing"	Thickness $\geq 0,5 \text{ mm}$ (dry layer thickness) Material: ablative coating material ArmaProtect CB acc. to ETA 22/0063 Classification of fire behavior according to EN 13501-1: E
50 mm thick mineral wood plates	"Rockwool Hardrock 040" Deutsche Rockwool Mineralwoll GmbH, 45866 Gladbeck, Germany; acc. to EN 13162 Classification of fire behavior acc. to EN 13501-1: A1
Mineral wool	"Rockwool Lose Wolle RL"; Deutsche Rockwool Mineralwoll GmbH, 45866 Gladbeck, Germany; acc. to EN 14303 Classification of fire behavior acc. to EN 13501-1: Class A1
32 mm thick system floor plates	"GIFAFloor FHB" Knauf Classification of fire behavior acc. to EN 13501-1: A1
Closure of the residual joint	Material: ArmaProtect CM acc. ETA 22/0064 Classification of fire behaviour acc. to EN 13501-1: A1
Closure of the residual joint	ArmaProtect MM20 Material: Fire protection mortar acc. to EN 998-2 Classification of fire behaviour acc. to EN 13501-1: A1
Cable wrap	Thickness = $1,5 \text{ mm}$; width = 125 mm Material: intumescent material ArmaProtect FW2 Classification of fire behavior acc. to EN 13501-1: Class C-s1,d0

Annex 2

Resistance to fire classification of ArmaProtect CT and ArmaProtect CT ML

Performance of cable penetration seals, tested with the construction product ArmaProtect CT or ArmaProtect CT ML

Service	Measure		Fire resistance class	
ArmaProtect CT Cable Tube – installation length 150 mm				
Cables, cable bundles	wall	floor	wall	floor
Cable $\varnothing \leq 21$ mm	-	-	EI 90 / E 120	EI 120
Cable $\varnothing \leq 50$ mm	-	only 100% configuration	-	EI 90 / EI 120
Cable bundle $\varnothing \leq 100$ %, with cable $\varnothing \leq 14$ mm	-		-	EI 120
Cable bundle $\varnothing \leq 100$ %, with cable $\varnothing \leq 21$ mm	-	Intumescent wrap 1x 1-layer, 50 mm overlap, above or below	EI 90 / E 120	EI 120
Electrical installation conduits (EIC)				
Conduits single $\varnothing \leq 40$ mm, with/without cable $\varnothing \leq 21$ mm	-	Max. 3 pcs.	-	EI 90 U/U
Conduits single $\varnothing \leq 40$ mm, with/without cable $\varnothing \leq 21$ mm	-	-	EI 90 U/U E 120 U/U	-
Conduit bundle, with or without configuration, $\varnothing \leq 90$ mm with conduit $\varnothing \leq 40$ mm, with/without cable $\varnothing \leq 21$ mm	-	-	EI 90 U/U 120 U/U	-
HVAC split line combinations				
Pipe $\varnothing 6-10$ mm/ $10-18$ mm + pipe insulation 9 mm thick made of PE foam + PE-100 outer- $\varnothing \leq 25$ mm, depth 1.5 mm (U/U) + max 3 cables $\varnothing \leq 14$ mm	-	-	EI 90 U/U	EI 90 U/U
Pipe 1/pipe 2 outer- $\varnothing 6-22$ mm/ $6-22$ mm + pipe insulation 9 mm thick made of PE foam + PE-100 outer- $\varnothing \leq 25$ mm, depth 1.5 mm (U/U) + max 3 cables $\varnothing \leq 14$ mm	-	Lamella mat ≥ 250 mm x ≥ 30 mm above	-	EI 120
Speedpipes, bundled or individually, with/without glass fibre cables				
7 mm $\leq \varnothing \leq 14$ mm bundle ≤ 100 %		-	EI 120 U/U	
max. 24 pcs. pipe outer- $\varnothing \leq 7$	-	-	-	EI 120 U/U
max. 7 pcs. pipe outer- $\varnothing \leq 10$ max. 5 pcs. pipe outer- $\varnothing \leq 12$	-	-	-	EI 120 U/U

Service	Measure		Fire resistance class	
ArmaProtect CT Cable Tube – Installation length 200 mm				
Cables, cable bundles	wall	floor	wall	floor
Cable $\varnothing \leq 21$ mm	–		EI 120	EI 120
Cable $\varnothing \leq 50$ mm	-	only 100% configuration	-	EI 90 / EI 120
Cable bundle $\varnothing \leq 100$ %, with cable $\varnothing \leq 14$ mm	–	-	-	EI 120
Cable bundle $\varnothing \leq 100$ %, with cable $\varnothing \leq 21$ mm	–	-	-	EI 60 / E 90
Cable bundle $\varnothing \leq 100$ %, with cable $\varnothing \leq 21$ mm	–	Intumescent wrap 1x 1-layer, 50 mm overlap, above or below	EI 120	EI 120
Electrical installation conduits (EIC)				
Conduits $\varnothing \leq 32$ mm, with/without cable $\varnothing \leq 14$ mm	–	max. 3 pcs.	-	EI 90 U/U
Conduits single $\varnothing \leq 40$ mm, with/without cable $\varnothing \leq 21$ mm	–	–	EI 120 U/U	–
Conduit bundle, with or without configuration, $\varnothing \leq 90$ mm with conduit $\varnothing \leq 40$ mm, with/without cable $\varnothing \leq 21$ mm	–	–	EI 120 U/U	–
Conduit bundle $\varnothing \leq 100$ % with conduit $\varnothing \leq 32$ mm, with/without cable $\varnothing \leq 21$ mm	–	–	EI 120 U/U	–
HVAC split line combinations				
Pipe 1/pipe 2 outer- \varnothing 6-10 mm/10-18 mm + pipe insulation 9 mm thick made of PE foam + PE-100 outer- $\varnothing \leq 25$ mm, depth 1.5 mm (U/U) + max 3 cables $\varnothing \leq 14$ mm	–	-	EI 90 U/U	EI 90 U/U
Pipe 1/pipe 2 outer- \varnothing 6-22 mm/ 6-22 mm + pipe insulation 9 mm thick made of PE foam + PE-100 outer- $\varnothing \leq 25$ mm, depth 1.5 mm (U/U) + max 3 cables $\varnothing \leq 14$ mm		Lamella mat ≥ 250 mm x ≥ 30 mm above		EI 120 U/U
Speedpipes, bundled or individually, with/without glass fibre cables				
7 mm $\leq \varnothing \leq 14$ mm bundle ≤ 100 %	–	–	EI 120 U/U	
max. 24 pcs. pipe outer- $\varnothing \leq 7$	–	–	-	EI 120 U/U
max. 7 pcs. pipe outer- $\varnothing \leq 10$ max. 5 pcs. pipe outer- $\varnothing \leq 12$	–	–	-	EI 120 U/U

Service	Measure		Fire resistance class	
	wall	floor	wall	floor
ArmaProtect CT Cable Tube – Installation length 300 mm				
Cables, cable bundles				
Cable $\varnothing \leq 21$ mm	-	-	EI 120	EI 120
Cable $\varnothing \leq 50$ mm	-	-	EI 90 / E 120	EI 60 / E 120
Cable $\varnothing \leq 50$ mm	-	100% configuration	-	EI 90 / E 90
Cable $\varnothing \leq 50$ mm	-	Lamella mat ≥ 100 mm x ≥ 30 mm + intumescent wrap x 1-layer, above	-	EI 120
Cable $\varnothing \leq 80$ mm	solid wall	-	EI 90 / E 120	EI 60 / E 120
Cable bundle $\varnothing \leq 100$ %, with cable $\varnothing \leq 21$ mm	-	-	EI 120	EI 120
Wave guides				
CommScope HELIAX LDF (low density foam), $\varnothing \leq 16,002$ mm	-	-	EI 120 U/C	-
CommScope 50 Ω braided CNT, $\varnothing \leq 15,0$ mm	-	-	EI 120 U/C	-
CommScope HELIAX AVA, $\varnothing \leq 28$ mm	-	-	E 120 U/C / EI 90 U/C	-
CommScope HELIAX FSJ (super flexible), $\varnothing \leq 13,5$ mm	-	-	E 120 U/C / EI 90 U/C	-
RFS RADIAFLEX RLK, $\varnothing \leq 28,5$ mm	-	-	EI 120 U/C	-
RFS CELLFLEX LCF, $\varnothing \leq 27,8$ mm	-	-	EI 120 U/C	-
Electrical installation conduits (EIC)				
Conduits single $\varnothing \leq 40$ mm, with/without cable $\varnothing \leq 21$ mm	-	-	EI 120 U/U	
Conduits single $\varnothing \leq 63$ mm, with/without cable $\varnothing \leq 21$ mm	-	-	-	EI 120 U/U
Conduit bundle, with or without configuration, with conduit $\varnothing \leq 40$ mm, $\varnothing \leq 90$ mm	-	-	EI 120 U/U	
Conduit bundle $\varnothing \leq 100$ % with conduit $\varnothing \leq 32$ mm, with/without cable $\varnothing \leq 21$ mm	-	-	EI 120 U/U	
Conduit bundle $\varnothing \leq 107$ mm with conduit $\varnothing \leq 32$ mm, with/without cable $\varnothing \leq 21$ mm	-	Floor ≥ 200 mm	-	EI 120 U/U

Service	Measure		Fire resistance class	
HVAC split line combinations				
Pipe 1/pipe 2 outer-Ø 6-10 mm/ 10-18 mm + pipe insulation 9 mm thick made of PE foam + PE-100 outer-Ø ≤ 25 mm, depth 1.5 mm (U/U) + max 3 cables Ø ≤ 14 mm	-	-	EI 90 U/U	EI 90 U/U
Pipe 1/pipe 2 outer-Ø 6-22 mm/ 6-22 mm + pipe insulation 9 mm thick made of PE foam + PE-100 outer-Ø ≤ 25 mm, depth 1.5 mm (U/U) + max 3 cables Ø ≤ 14 mm	-	Lamella mat ≥ 250 mm x ≥ 30 mm above	-	EI 120 U/U
Speedpipes, bundled or individually, with/without glass fibre cables				
7 mm ≤ Ø ≤ 14 mm bundle ≤ 100 %	-	-	EI 120 U/U	-
max. 24 pcs. pipe outer-Ø ≤ 7	-	-	-	EI 120 U/U
max. 7 pcs. pipe outer-Ø ≤ 10 max. 5 pcs. pipe outer-Ø ≤ 12	-	-	-	EI 120 U/U
Combustible pipes made of PVC-U				
Pipe outer Ø 20 mm x s 1.5 mm up to pipe outer Ø 32 mm x s 2.4 mm	-	-	EI 120 U/U	-

The tested/ illustrated cable penetration seals in annex 6 are only examples for the use.
The Illustrations are without guarantee for completeness.

The use of the construction products ArmaProtect CT Cable Tube and ArmaProtect CT ML Cable Tube in cable penetration seals shall be in accordance with national requirements for planning, design and execution and in accordance with the installation instruction of the manufacturer.

Annex 3 Construction of pipe sleeve ArmaProtect CT, variants 1 and 2

ArmaProtect CT Cable Tube

ArmaProtect CT Cable Tube

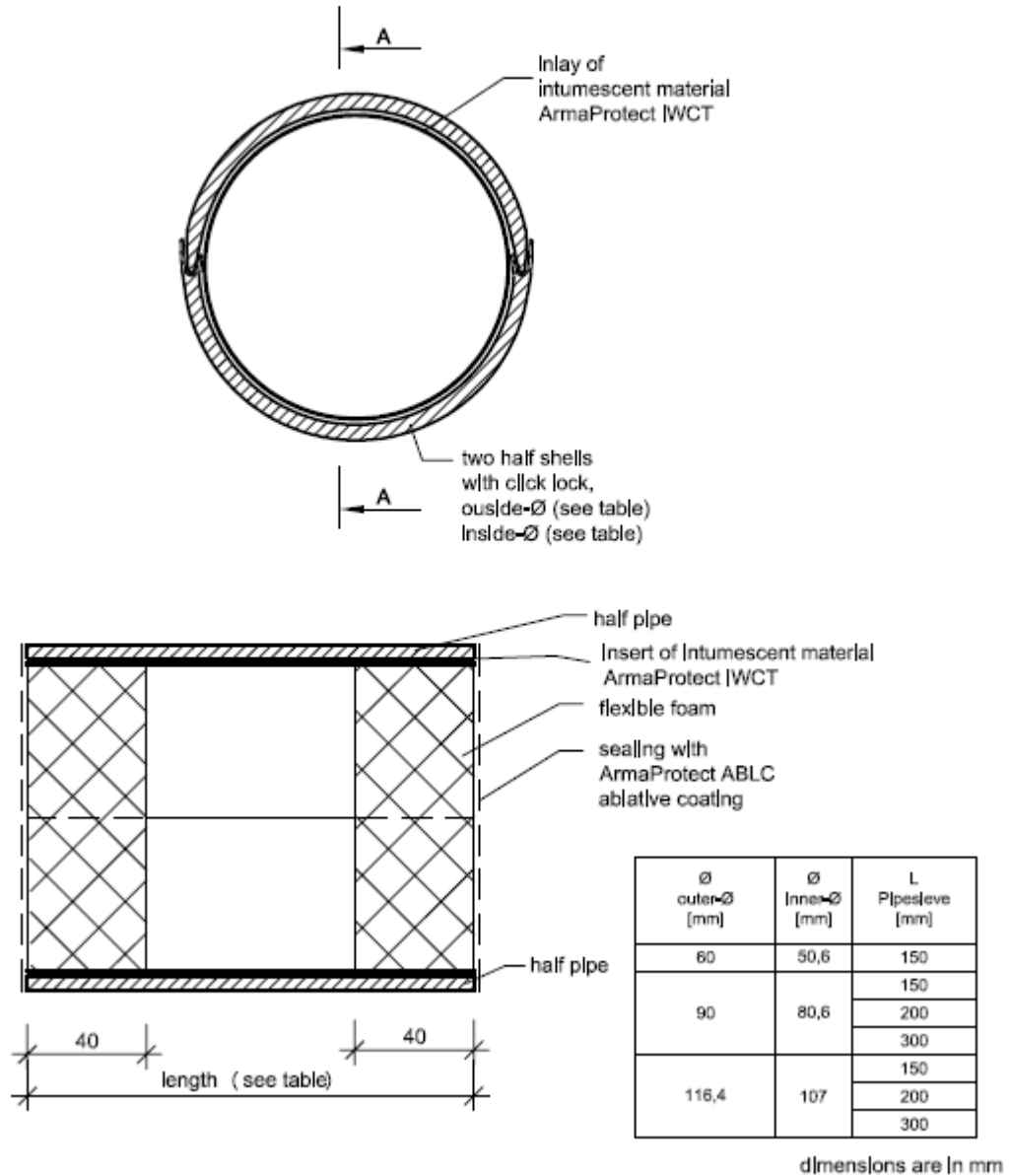

Annex 4 Construction of pipe sleeve ArmaProtect CT ML

ArmaProtect CT ML Cable Tube

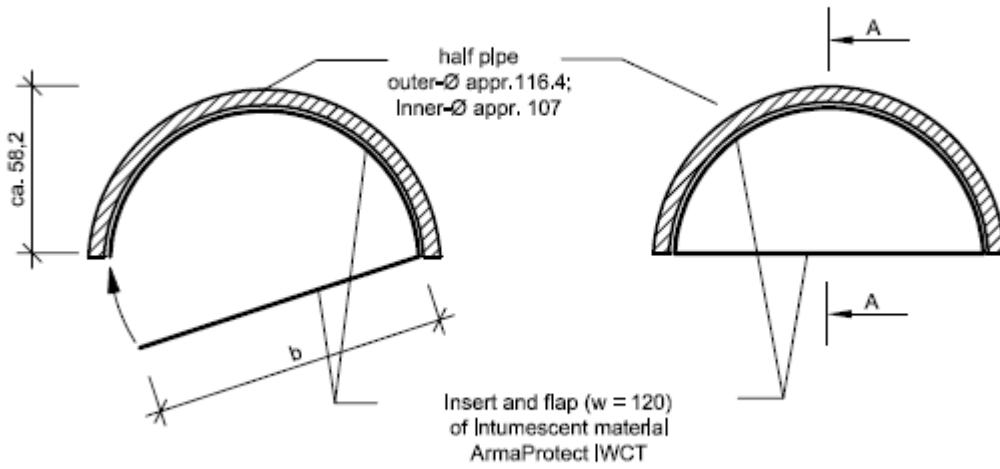

Section A - A

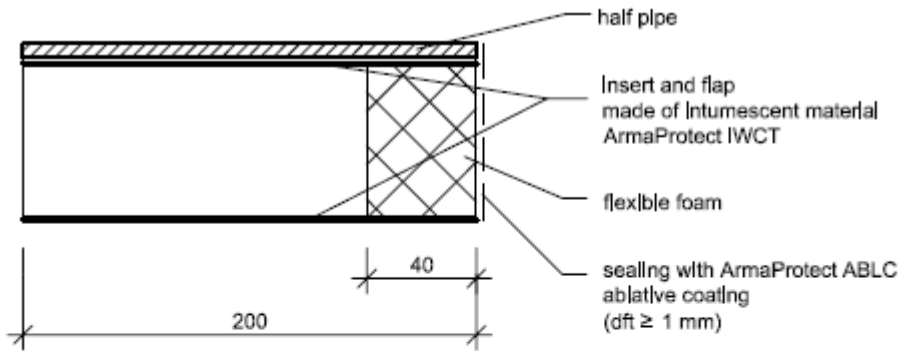

closure and sealing are needed on one side only!

dimensions are in mm

Annex 5

Example for cable penetration seals using the pipe sleeve ArmaProtect CT

ArmaProtect CT Cable Tube

Intersection, wall construction

Intersection, floor construction

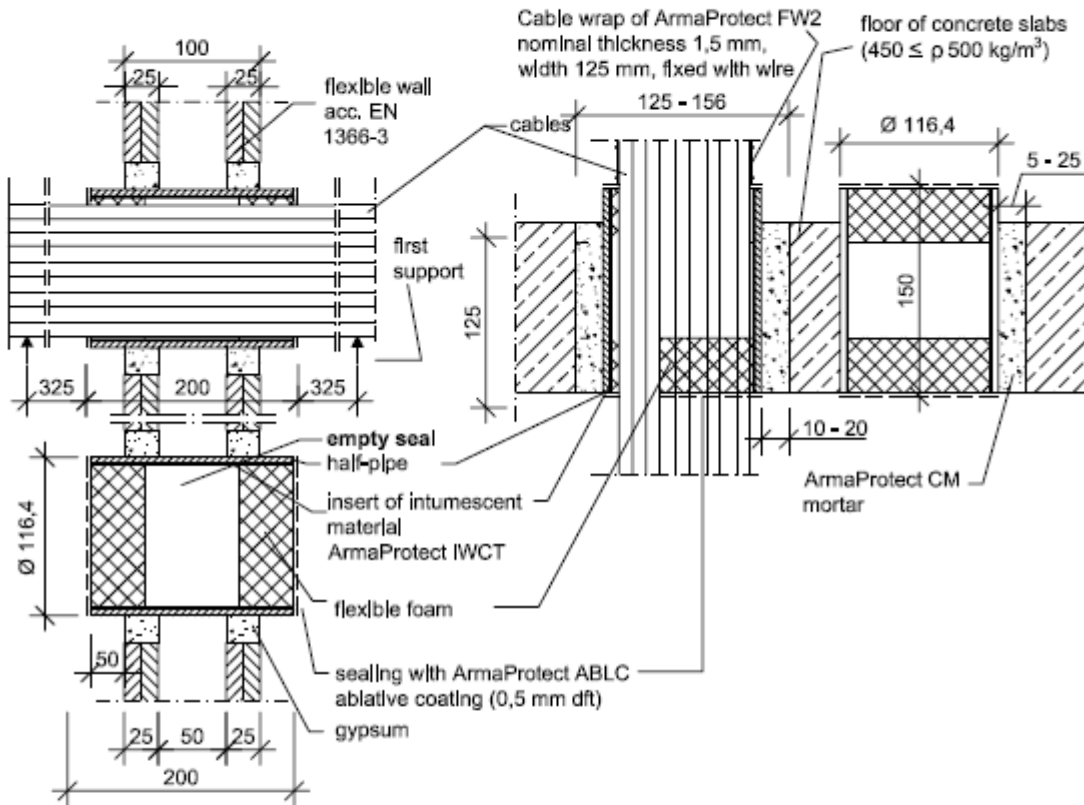

View, wall construction

View, floor construction

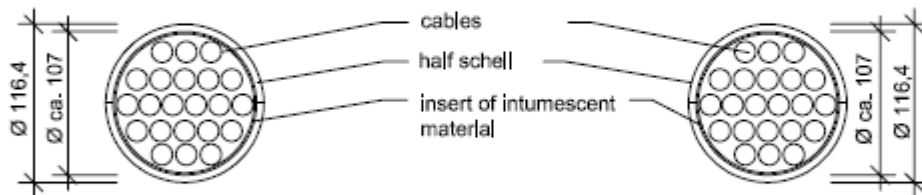

Configuration wall construction;
 F-telecommunication cables, cablebundle \varnothing 100 mm
 100% configuration of telecommunication cables
 with PVC-insulation and copperwire
 Type J-Y (St)Y 80 x 2 x 0,6 LG grey; \varnothing appr. 21 mm

Configuration floor construction;
 F-telecommunication cables, cablebundle \varnothing 107 mm
 100% configuration of telecommunication cables
 20 x 2 x 0,6 mm
 Type A2-Y (L) 2Y St III BD, Insulation PE / PE

dimensions are in mm

ArmaProtect CT Cable Tube with single cables in walls or floors

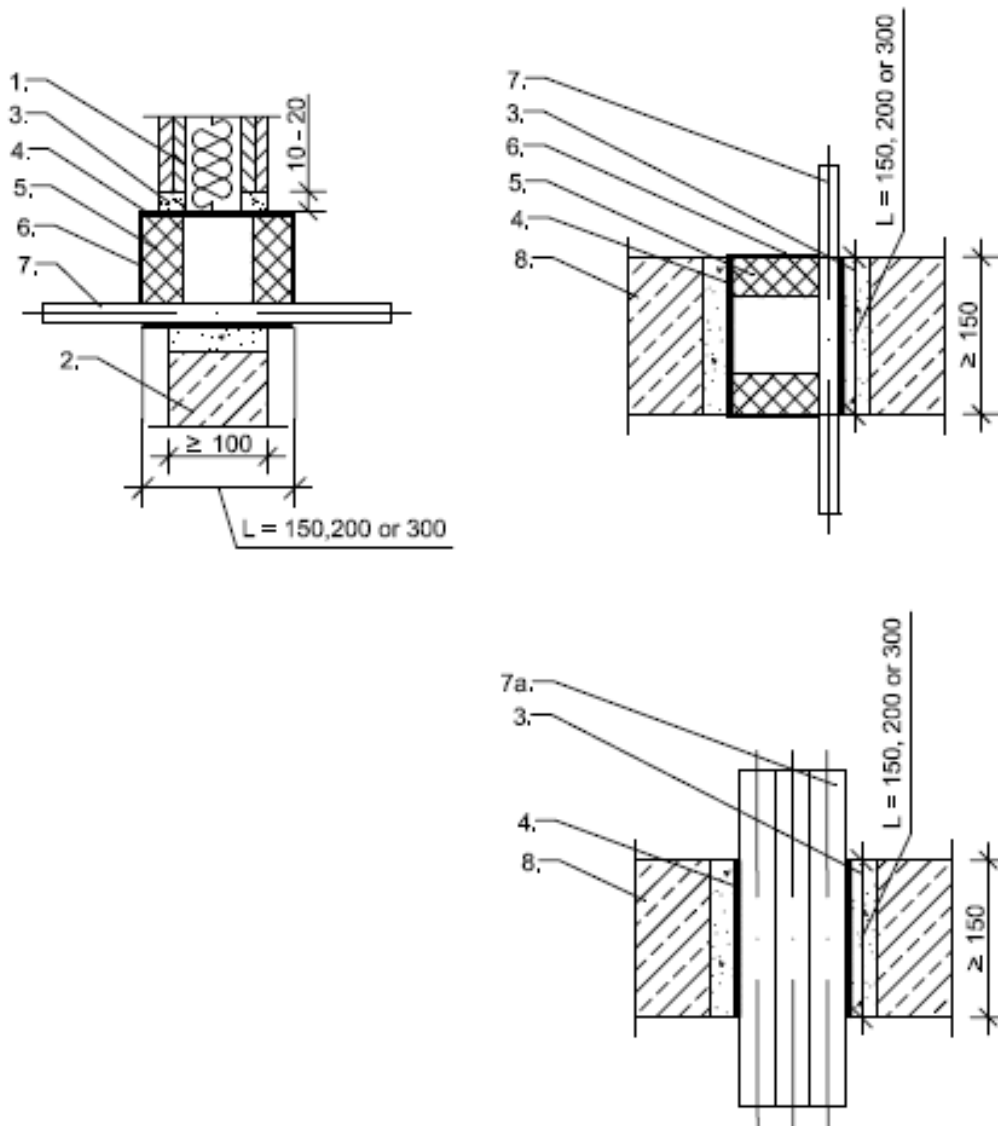

- 1. flexible wall
- 2. rigid wall
- 3. mortar or gypsum
- 4. Cable Tube
- 5. Melamin resin stopper
- 6. ablative coating
- 7. cable (for details see table)
- 7a. cable $\varnothing \leq 50$ mm (100% configuration)
- 8. floor

dimensions in mm

ArmaProtect CT Cable Tube with cable bundles in walls or floors without additional measures

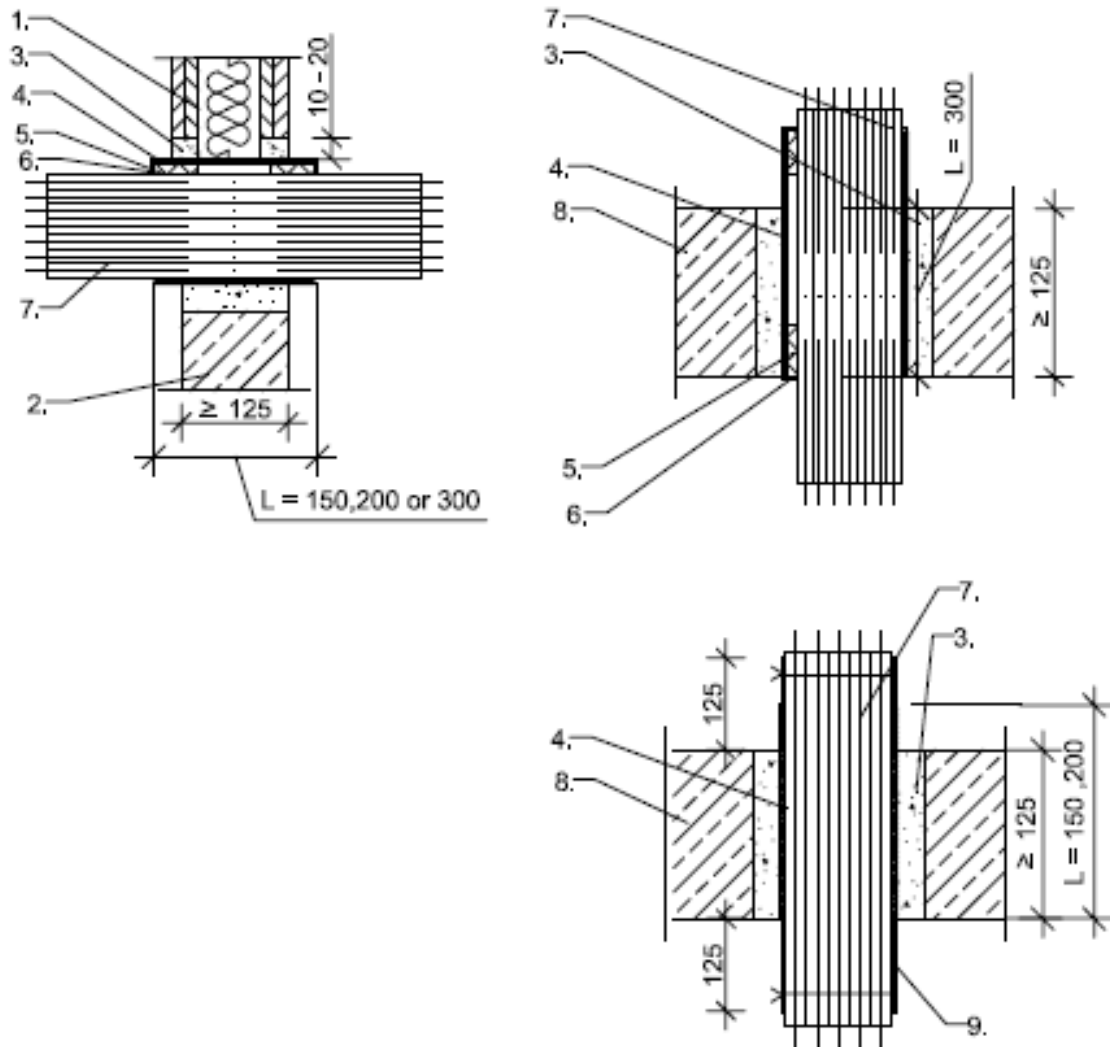

1. flexible wall
2. rigid wall
3. mortar or gypsum
4. Cable Tube
5. Melamin resin stopper
6. ablativ coating
7. cablebundle $\varnothing \leq 100$ mm (for details see table)
8. floor
9. Intumescent wrap (above or below)

dimensions in mm

ArmaProtect CT Cable Tube with conduits, single or bundled, with or without cables in walls or floors

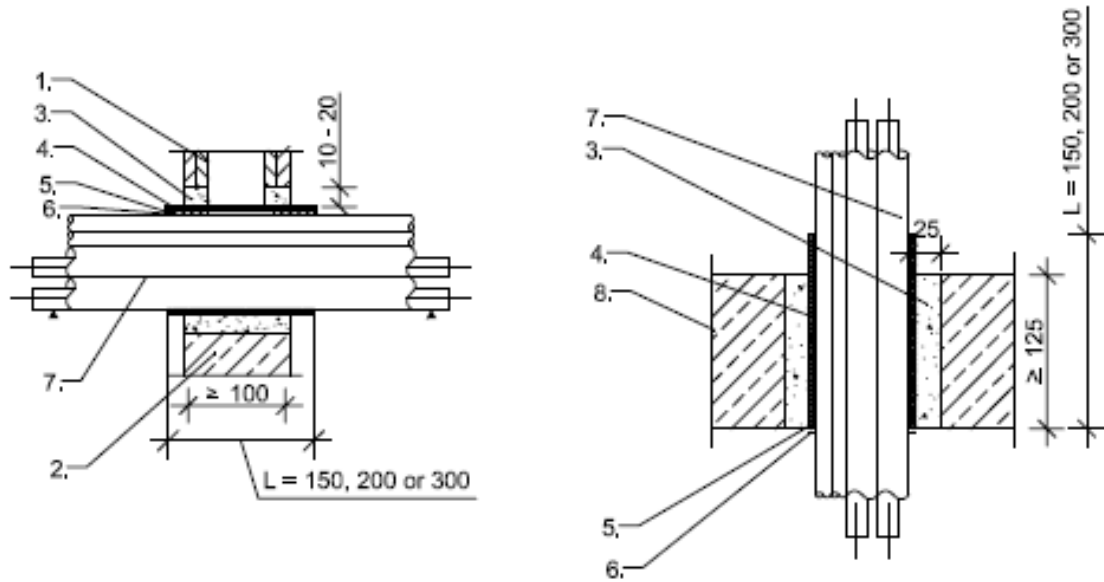

- 1. flexible wall
- 2. rigid wall
- 3. mortar or gypsum
- 4. Cable Tube
- 5. Melamin resin stopper
- 6. ablative coating
- 7. conduits (with or without cables)
- 8. floor

dimensions in mm

ArmaProtect CT Cable Tube HVAC split line combinations in walls or floors

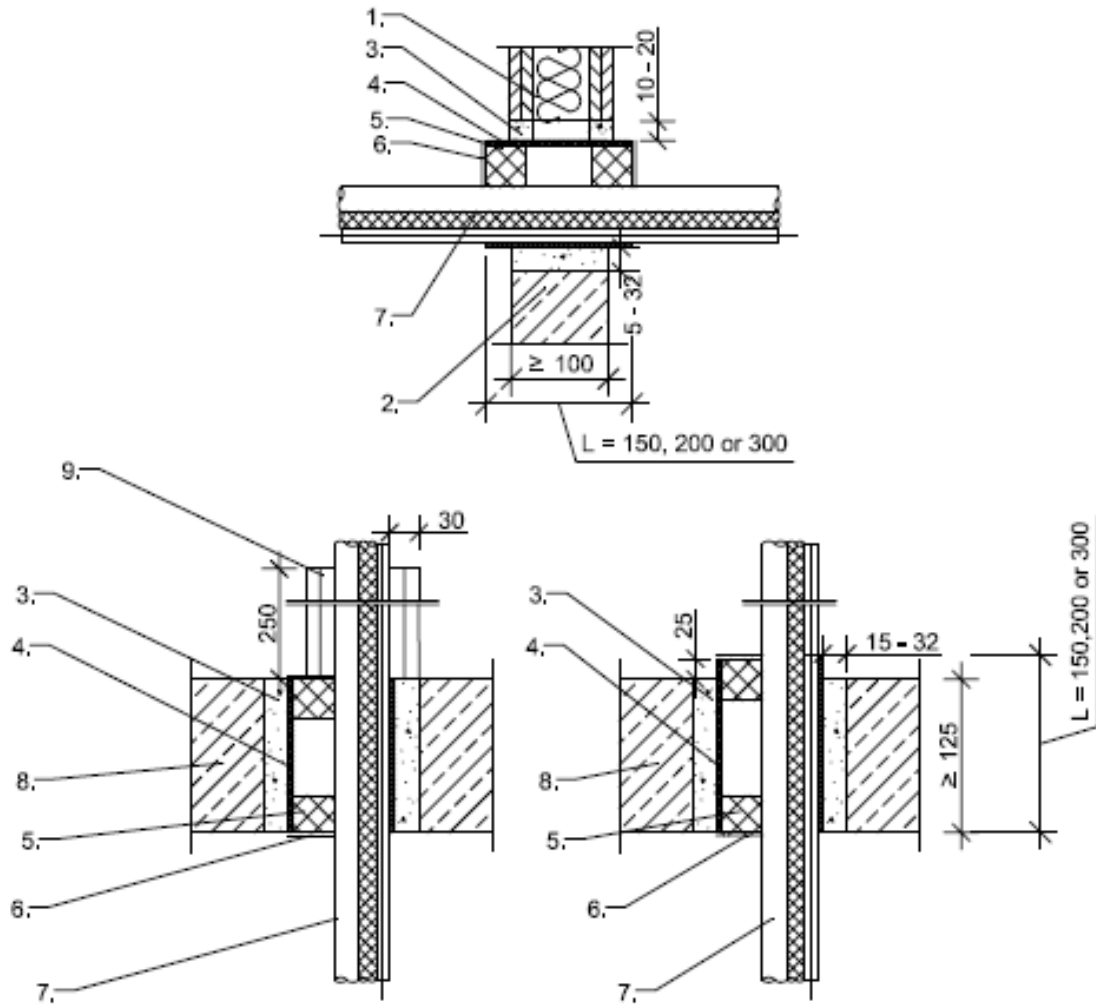

- 1. flexible wall
- 2. rigid wall
- 3. mortar or gypsum
- 4. Cable Tube
- 5. Melamin resin stopper
- 6. ablativ coating
- 7. HVAC split lines combinations
- 8. floor
- 9. lamella mat

dimensions in mm

ArmaProtect CT Cable Tube with speed pipes, single or bundles, with or without glass fibre cables in floors

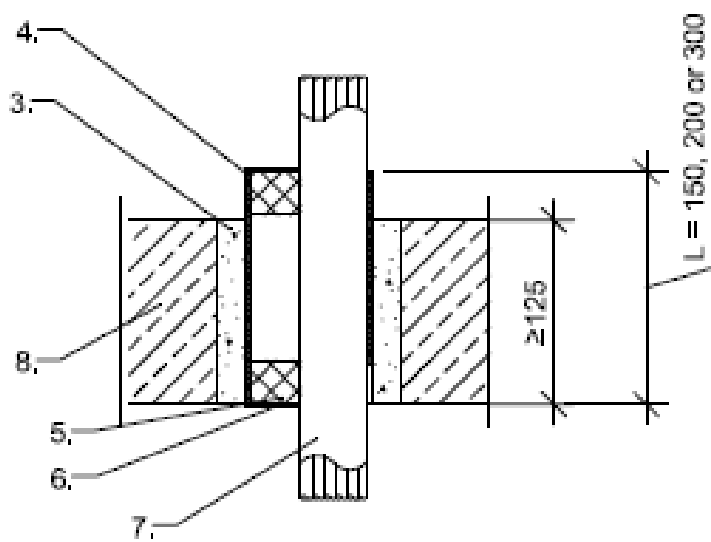

- 3. mortar or gypsum
- 4. Cable Tube
- 5. Melamin resin stopper
- 6. ablativ coating
- 7. speed pipes
- 8. floor

dimensions in mm

ArmaProtect CT Cable Tube with combustible pipes of PVC-U in walls

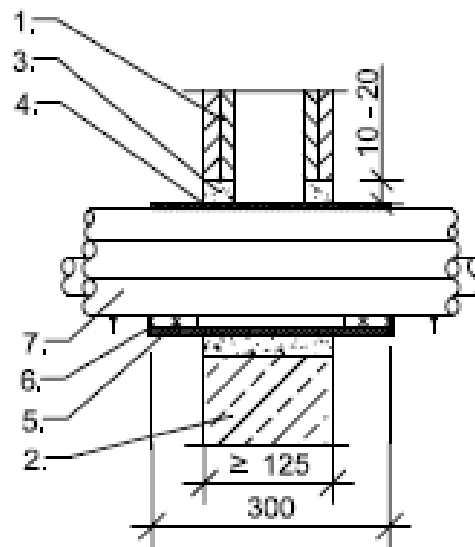

1. flexible wall
2. rigid wall
3. mortar or gypsum
4. Cable Tube
5. Melamin resin stopper
6. ablative coating
7. combustible pipes

dimensions in mm

ArmaProtect CT Cable Tube with wave guides in walls

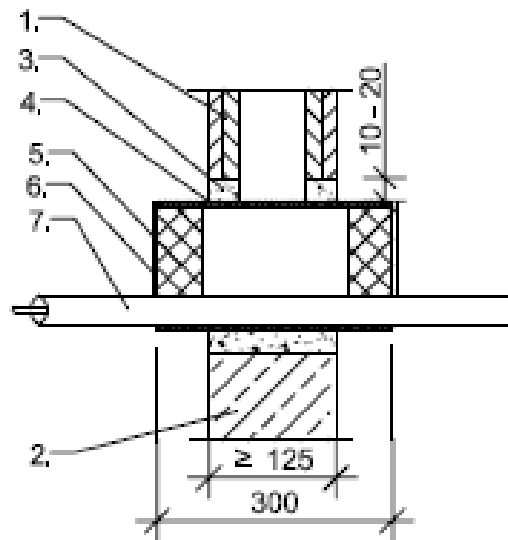

1. flexible wall
2. rigid wall
3. mortar or gypsum
4. Cable Tube
5. Mejam resin stopper
6. ablative coating
7. wave guide

dimensions in mm

ArmaProtect CT ML Cable Tube"

View

Example 1 (EI 90)
 configuration:
 1x C2-cable 4 x 95²
 1x E-cable 1 x 185²

Example 2 (EI 120)
 configuration:
 3 x A1-cable 5 x 1,5²
 3 x A2-cable 5 x 1,5²
 3 x A3-cable 5 x 1,5²
 1 x B-cable 1 x 95²

Example 3 (EI 120)
 configuration:
 conduit with 1 x A1 Kabel 5 x 1,5²
 conduit with 1 x A2-Kabel 5 x 1,5²
 conduit with 1 x A3-Kabel 5 x 1,5²
 conduit empty
 conduit empty
 (conduit sealed on one side)
 Example 4 (EI 120)
 blank seal

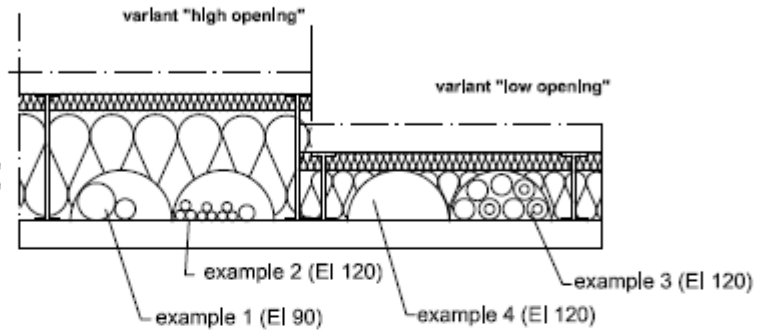

Intersection view

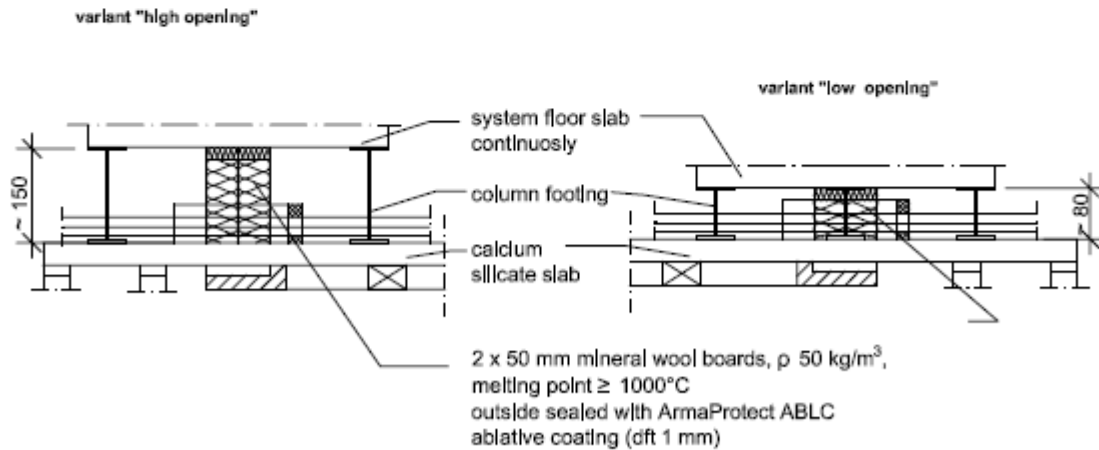

dimensions are in mm